

5 Dimensions and Panel Cut-out

Dimensions of ZM-62E

Unit : mm

● Bottom View

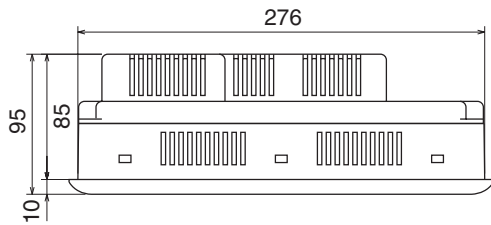

● Rear View

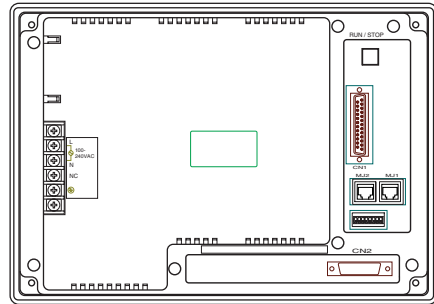

● Front View

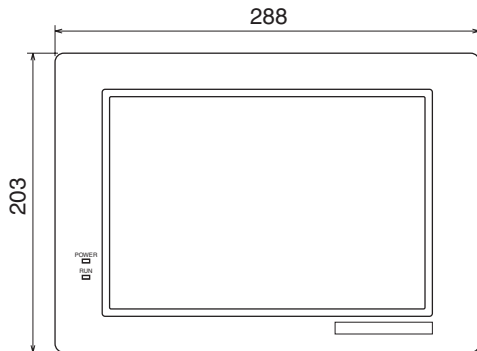

● Side View

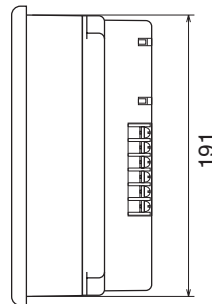

Panel Cut-out of ZM-62E

Unit : mm

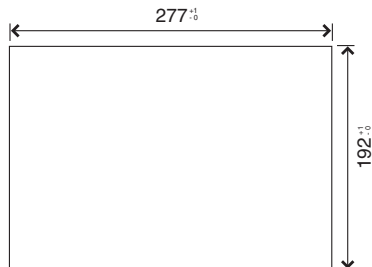

Panel Cut-out

6 Mounting Procedure

Follow the procedure shown below when you fix a ZM-62E to a mounting board.

1. Cut out the mounting panel (Max. thick: 5 mm) to match the dimensions shown below.

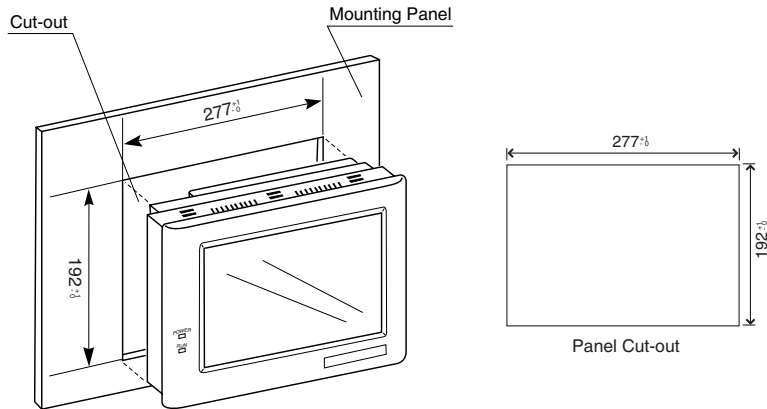

2. Insert 4 pieces of the fixtures attached to ZM-62E into the mounting holes on ZM-62E. Tighten them with the locking screws.

Screws	: 4 pcs
Screw Size	: M3
Torque	: 0.3~0.5 N·m (3~5 kgf·cm)

* Never use 6 pieces of the fixtures to mount ZM-62E.

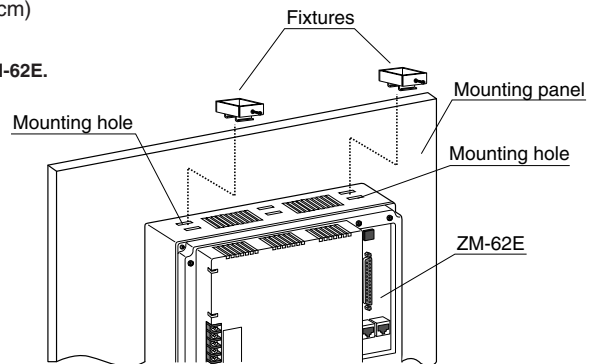
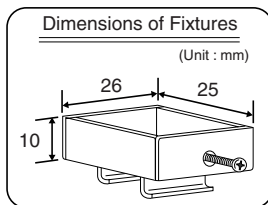

Mounting Angle

The unit (ZM-62E) shall be installed within the angle of 0 to 135 degrees as shown below.

