

# Chapter 4: Installation and Wiring

## 4-1 Installation

### [1] In case of ZM-61E

- ① Make a hole (size:  $192^{+0.5}_0 \times 277^{+0.5}_0$  mm) on the installation section (thickness: 6 mm at maximum) and install the control terminal.

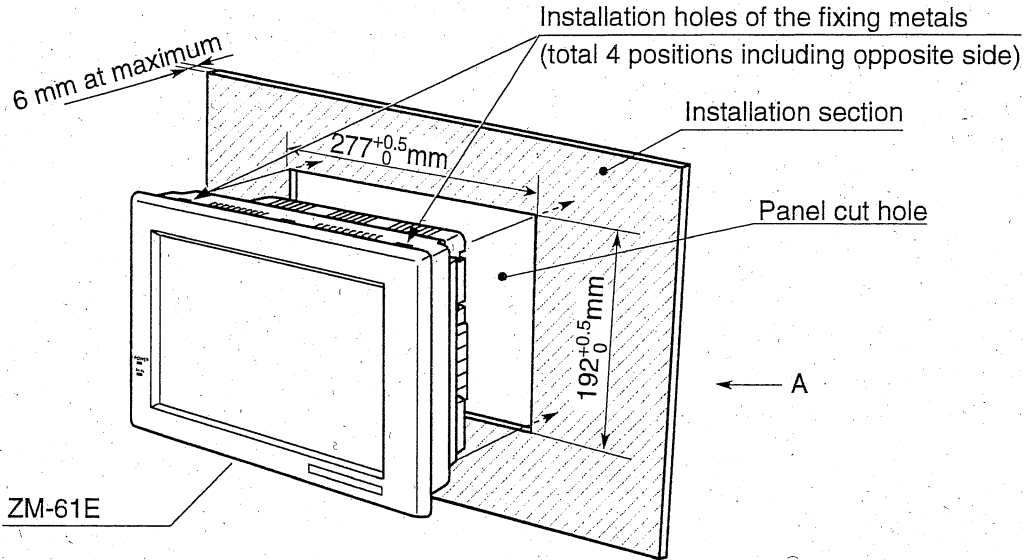

- ② Insert the fixing metals (4 pieces) supplied with the control terminal into installation holes (4 positions) of the body. Tighten the retention screws of the fixing metal to the control terminal on an installation section of the panel.

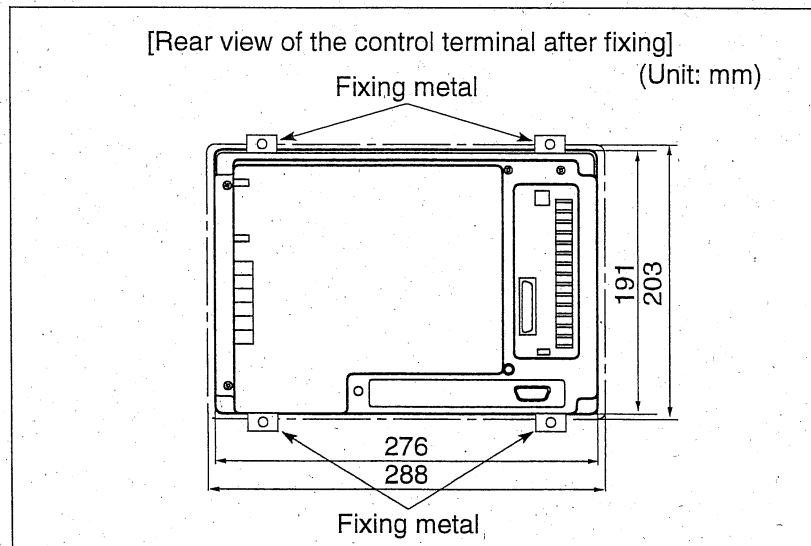
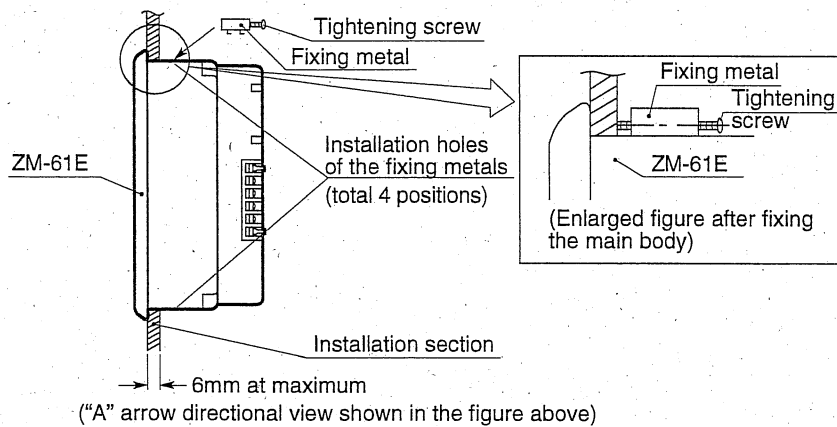

## 5-4 Outside dimensional drawings

[1] In case of ZM-61E

(Unit : mm)

· Front view

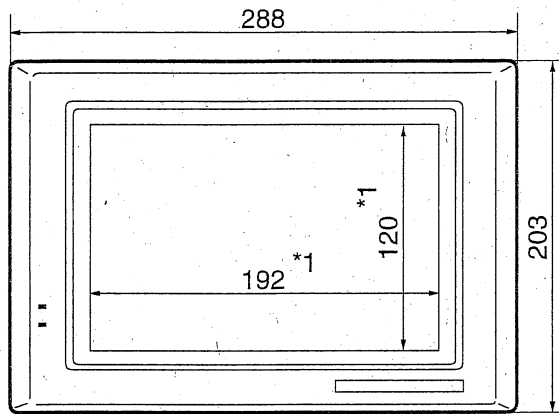

\*1 Available display area

· Right side view

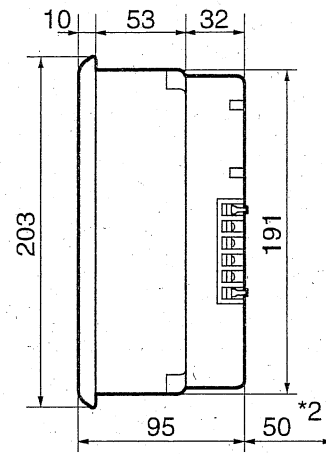

\*2 Leave a minimum of 50mm for wiring the connector connection cable. (on the back of the main housing)

· Plan view

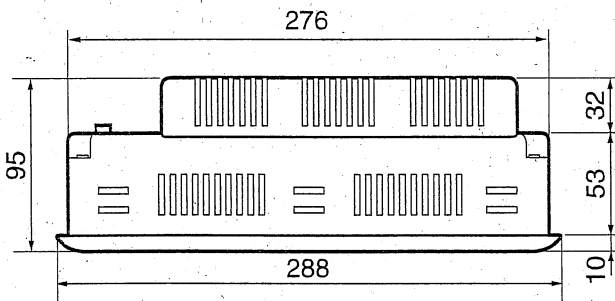

· Rear view

