

## ZM-370 Series External View and Dimensions

(Unit: mm)

- Side View

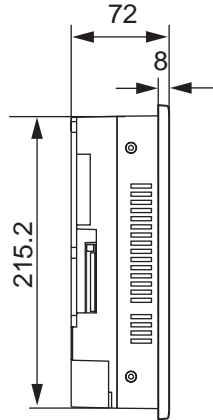

- Front View

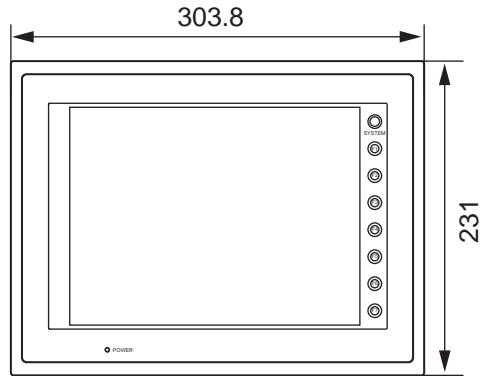

- Rear View

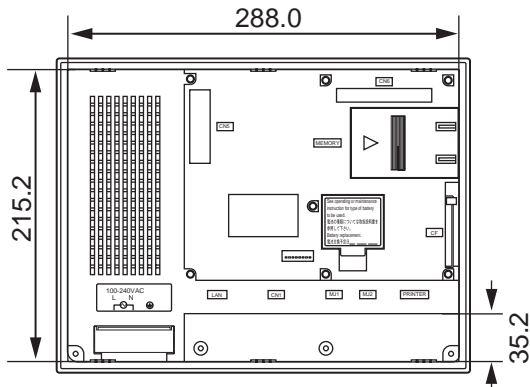

- Bottom View

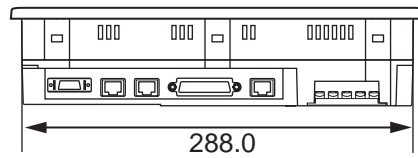

- Panel Cut-out Dimensions

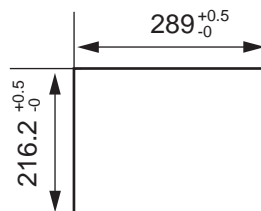

# 7. Mounting Procedure

## Mounting Procedure

- Cut out the mounting panel (max. thick: 5 mm) to match the dimensions shown below.

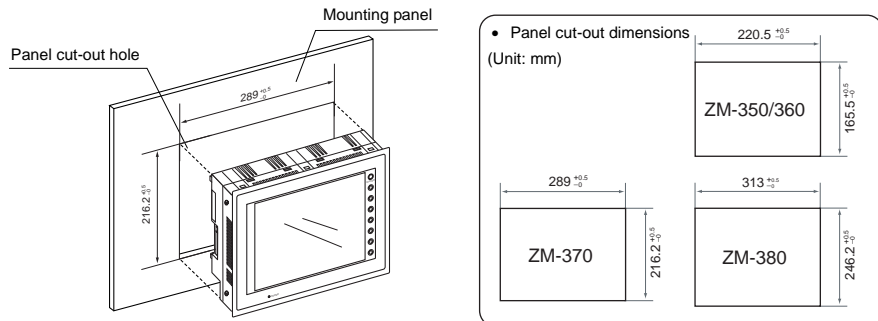

- Insert four fixtures attached to the ZM-300 series into the mounting holes, and tighten them with the locking screws.

Tightening torque

ZM-350/360/370: 0.3 to 0.5 N•m

ZM-380: 0.5 to 0.7 N•m

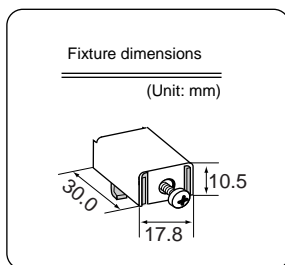

\* When the ZM-300 unit is attached to the mounting panel, the fixtures and frame grounds (FG) are connected. To prevent static electricity, be sure to connect the mounting panel to the frame ground.

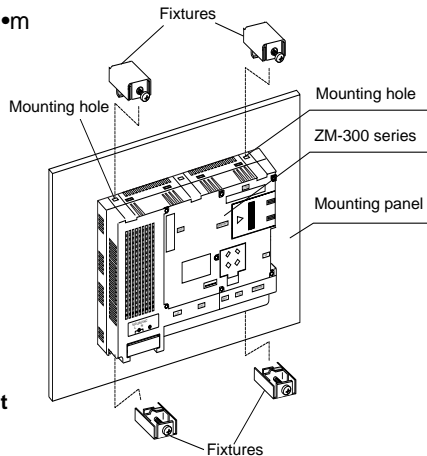

- Mount the gasket in contact with the mounting panel so that it will be sandwiched securely between the unit and the mounting plate.

## Mounting Angle

Install the unit within the angle of 15° to 135° degrees as shown on the right.

- When the mounting angle is between 15° and 45° or when you use the option module, ZM-301EU (video input and audio output), adjust the ambient temperature between 0°C and +40°C.

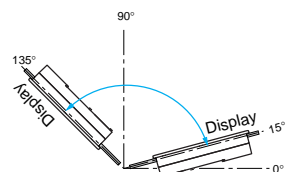

## Mounting Margin

About marginal space for connecting to the serial connector (CN1), see the figures below.

● ZM-350/360 series

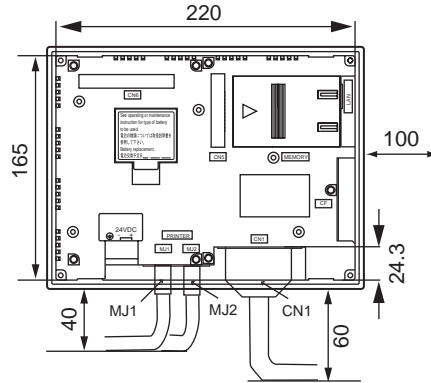

● ZM-370 series

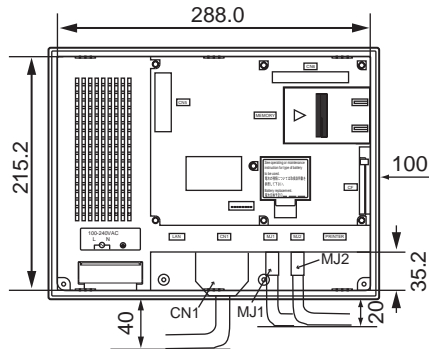

● ZM-380 series

